

Product Dimensions

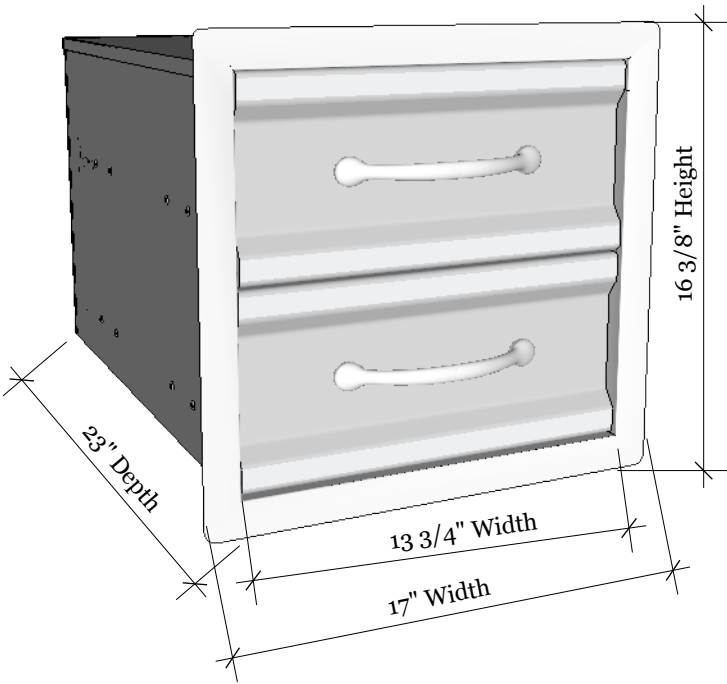

Cut-Out Dimensions

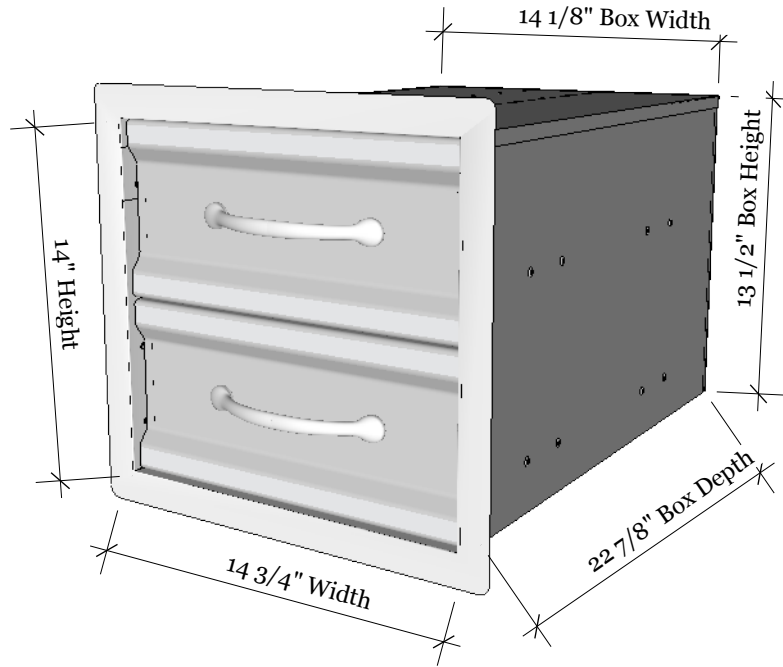

DBA Design Backyard
Austin TX 78681
Tel: 888.388.3366
Fax: 512.358.4049

PRODUCT
SUN PREMIUM DOUBLE ACCESS DRAWER
Item No. C-DD14

DESCRIPTION
304 stainless construction, flush mounted Polished Look. Drawers are fully enclosed.

Premium Double Access Drawer
17"W x 16-3/8"H x 23"D(Product Size)
14-3/4"W x 14"H (Cut-out)
42 LBS (Weight)

Material Specifications:
304 stainless steel
16 Gauge for Frame
18 Gauge for Panel
18 Gauge galvanized Box
Handles are made of zinc alloy, chrome plated.

ISO VIEW

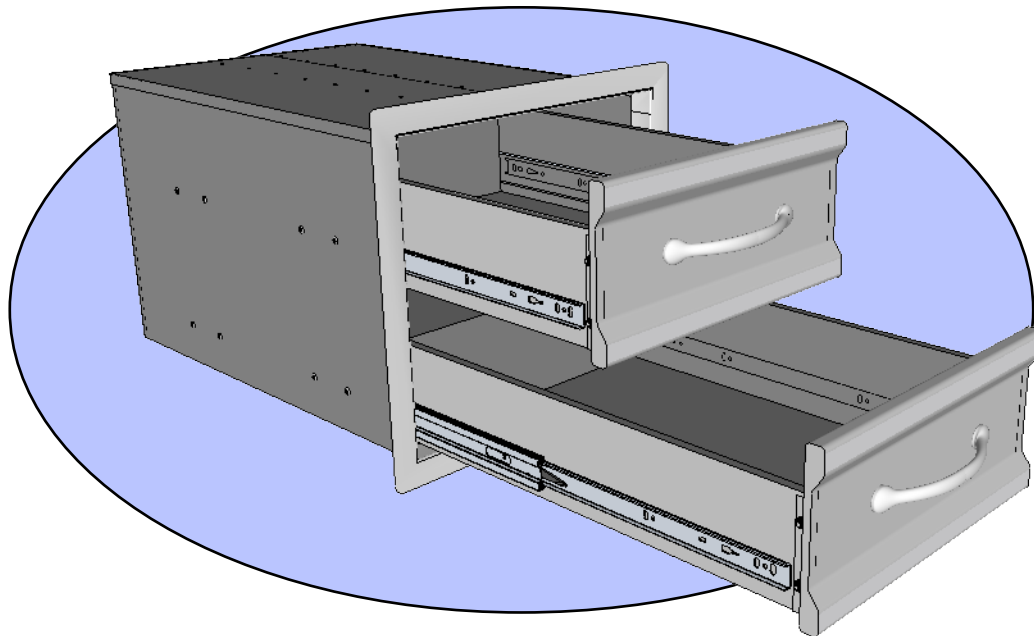

Drawer Extension

