

Product Dimensions

Cut-Out Dimensions

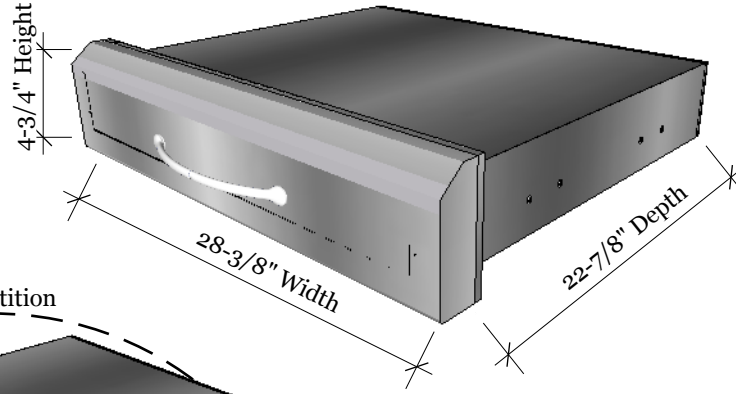
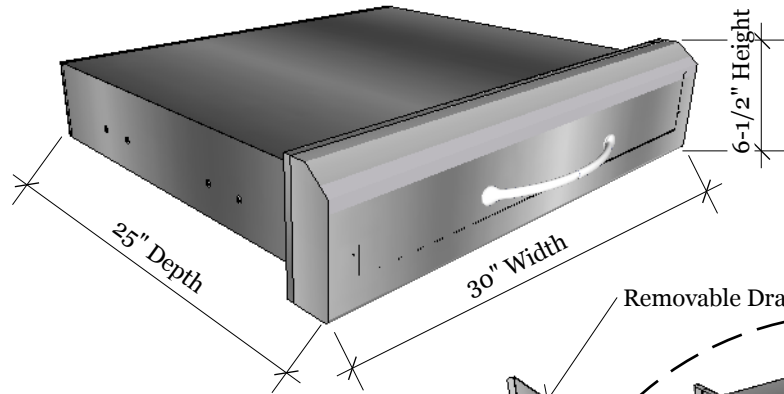

PRODUCT
SUN 30" X 6-1/2" PREMIUM DRAWER
 Item No. A-SD30

DESCRIPTION
 This 30 Inch Barbecue Island Drawers with Removable Space Divider, Constructed of commercial grade 304 Stainless Steel with heavy duty rails to ensure easy opening and closing, providing abundant space. Great for Outdoor Kitchen.

SUN 30" X 6-1/2" PREMIUM Drawer
 30"W x 6.5"H x 25"D (Product Size)
 28-3/8"W x 4-3/4"H x 22-7/8"D (Cut-out)
 42 LBS (Product Weight)
 46 LBS (Total Weight)

Material Specifications:
 18 gauge 304 stainless steel for frame.
 20 gauge 304 for drawer cabinet.
 18 gauge galvanized sheet for the box.
 Handles are made of zinc alloy, chrome plated.

1-7/8" Drawer Face Depth

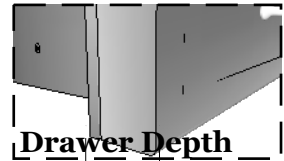

Drawer Depth

2-1/2" Total Depth w/Flange

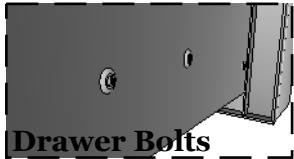

Drawer Bolts

Large 11-1/2" Handle

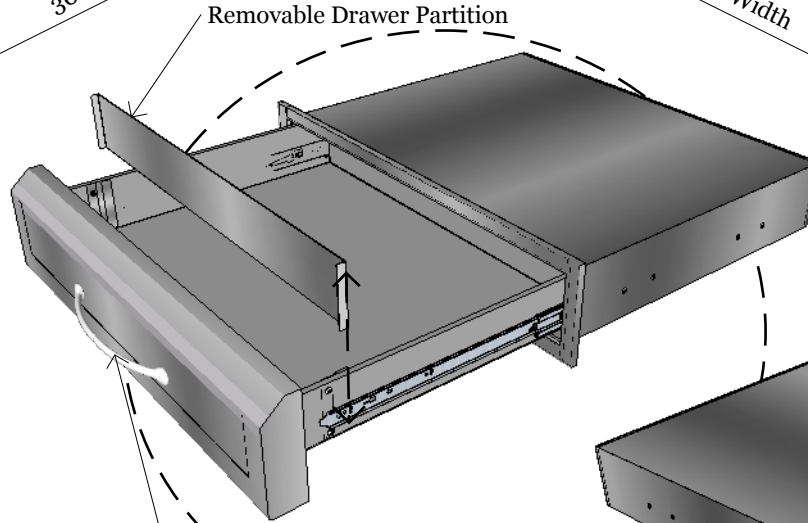

Removable Drawer Partition

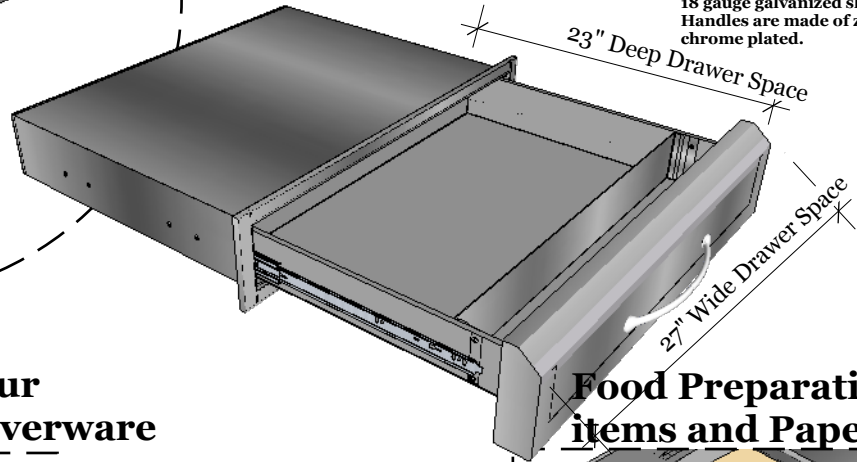

Food Preparation items and Paper Towels

Use as Storage for all your BBQ Accessories and Silverware

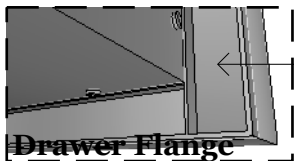

1" Flange

Drawer Flange

4" Depth

4" Inside Drawer Pocket, with Removable divider

Drawer Partition

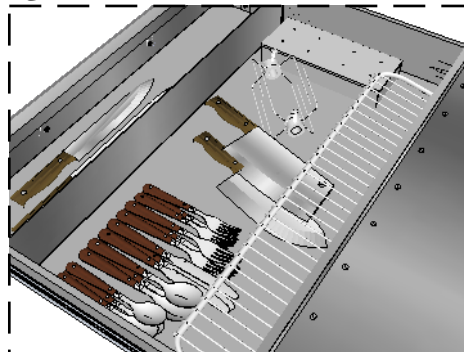

Two Drain Holes under Drawer front Face



Drawer Drains

