

Product Dimensions

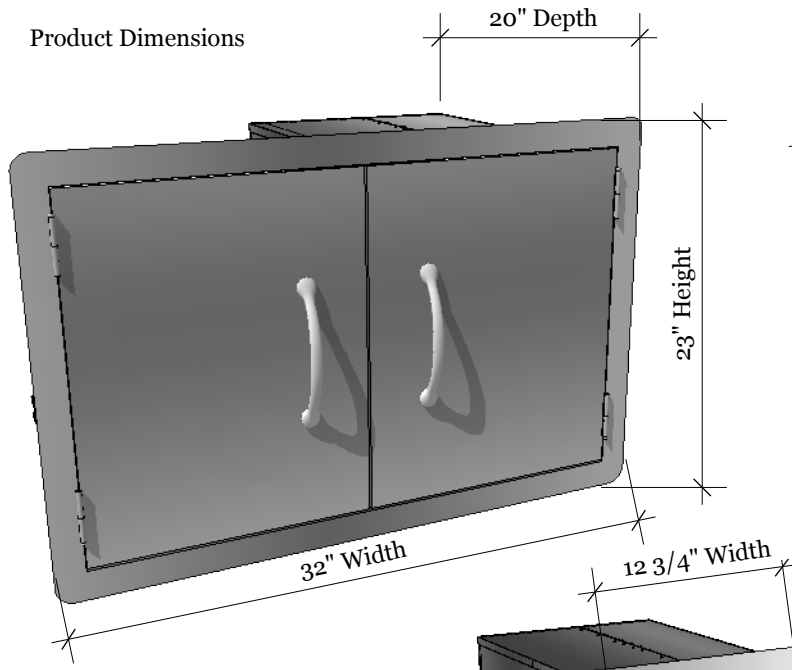

Cut-out Dimensions

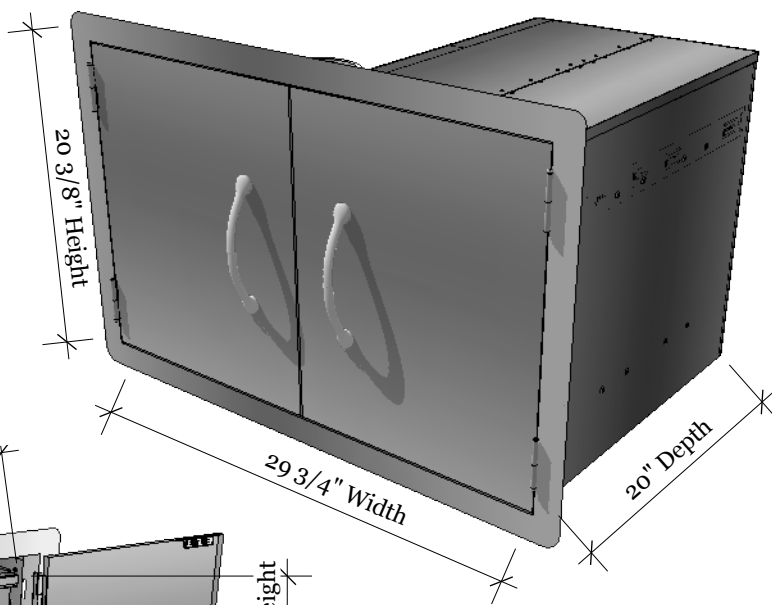

Design Backyard Inc.
 15508 Bratton Lane
 Austin Texas 78728
 Tel: 888.388.3366
 Fax: 512.358.4049

PRODUCT
 SUN DOUBLE DOOR/TANK TRAY COMBO
 Item No. A-LPDC

DESCRIPTION
 304 stainless construction, flush mounted. Drawers are fully enclosed. Propane tank storage is open in the back to allow for ventilation.

Double Door/Tank Tray Combo Drawers
 32" W x 23" H x 20" D (Product Size)
 29-3/4" W x 20-3/8" H x 20" D (Cut-out)
 60.5 LBS (Weight)

Material Specifications:
 304 stainless steel
 16 Gauge for Frame and Panel.
 20 gauge 201 SS for Box.
 Handles are made of zinc alloy, chrome plated.

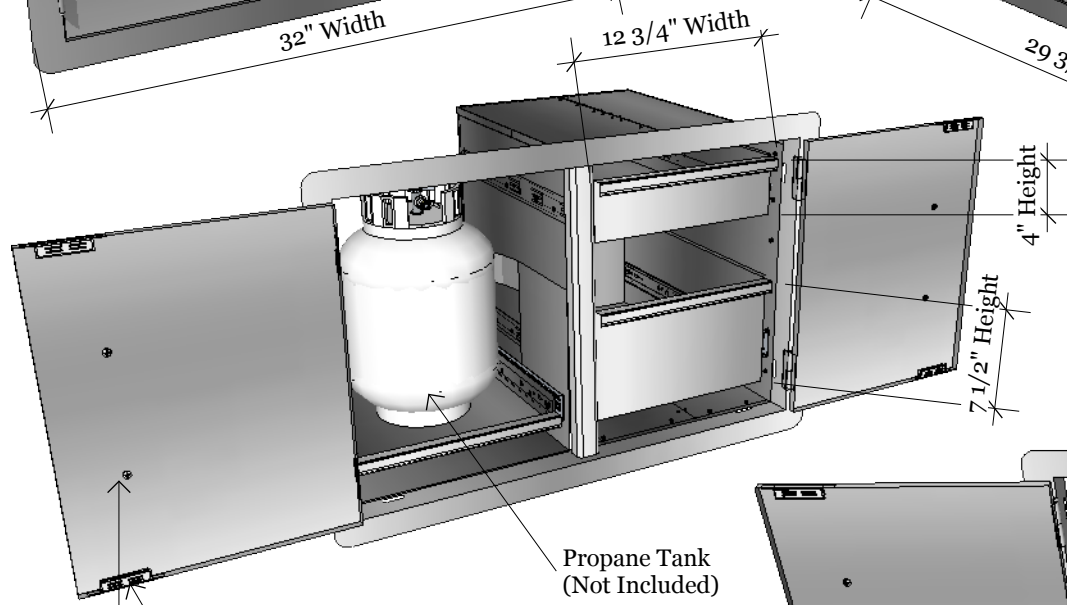

Top & Bottom Door Clip-on Magnets

Door Handles are spaced in, to for more secure door opening and closing.

